

# TECH 3232

## Lab #10

Fall 2024

## 555 Timer

V2.22

### **Background:**

The 555 timer is a versatile and widely used IC device because it can be configured in two different modes as either a monostable multivibrator (one-shot) or as an astable multivibrator (pulse oscillator)<sup>1</sup>

Astable operation<sup>2</sup>: Figure 9b shows the 555 connected as an astable multivibrator. Both the trigger and threshold inputs (pins 2 and 6) to the two comparators are connected together and to the external capacitor. The capacitor charges toward the supply voltage through the two resistors, R1 and R2. The discharge pin (7) connected to the internal transistor is connected to the junction of those two resistors.

When power is first applied to the circuit, the capacitor will be uncharged, therefore, both the trigger and threshold inputs will be near zero volts (see Fig. 10). The lower comparator sets the control flip-flop causing the output to switch high. That also turns off transistor T1. That allows the capacitor to begin charging through R1 and R2. As soon as the charge on the capacitor reaches 2/3 of the supply voltage, the upper comparator will trigger causing the flip-flop to reset. That causes the output to switch low. Transistor T1 also conducts. The effect of T1 conducting causes resistor R2 to be connected across the external capacitor. Resistor R2 is effectively connected to ground through internal transistor T1. The result of that is that the capacitor now begins to discharge through R2.

The only difference between the single 555, dual 556, and quad 558 (both 14-pin types), is the common power rail. For the rest everything remains the same as the single version, 8-pin 555.

As soon as the voltage across the capacitor reaches 1/3 of the supply voltage, the lower comparator is triggered. That again causes the control flip-flop to set and the output to go high. Transistor T1 cuts off and again the capacitor begins to charge. That cycle continues to repeat with the capacitor alternately charging and discharging, as the comparators cause the flip-flop to be repeatedly set and reset. The resulting output is a continuous stream of rectangular pulses.

The frequency of operation of the astable circuit is dependent upon the values of R1, R2, and C. The frequency can be calculated with the formula:

$$f = \frac{1.44}{C * (R1 + 2 * R2)}$$

---

<sup>1</sup> Floyd 10<sup>th</sup> Ed page 390

<sup>2</sup> <http://www.sentex.ca/~mec1995/gadgets/555/555.html>

The Frequency  $f$  is in Hz,  $R1$  and  $R2$  are in ohms, and  $C$  is in farads. The time duration between pulses is known as the 'period', and usually designated with a 't'. The pulse is on for  $t1$  seconds, then off for  $t2$  seconds. The total period ( $t$ ) is  $t1 + t2$  (see fig. 10). That time interval is related to the frequency by the familiar relationship:

$$f = \frac{1}{t} \text{ or } t = \frac{1}{f}$$

The time intervals for the on and off portions of the output depend upon the values of  $R1$  and  $R2$ . The ratio of the time duration when the output pulse is high to the total period is known as the duty-cycle. The duty-cycle can be calculated with the formula:

$$D = \frac{t1}{t} = \frac{R1 + R2}{R1 + 2 * R2}$$

You can calculate  $t1$  and  $t2$  times with the formulas below:

$$t1 = 0.693(R1 + R2) * C$$

$$t2 = 0.693 * R2 * C$$

**Procedure:**

Given the circuit diagram below:

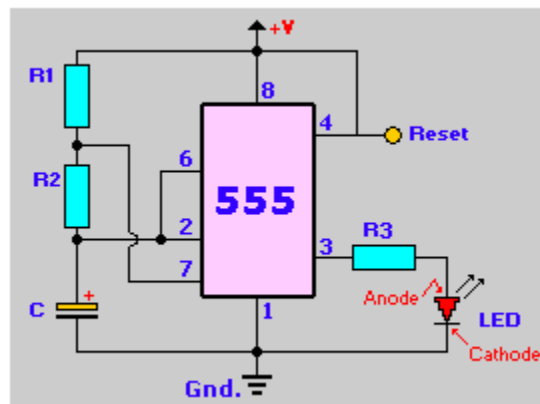

Figure 1- Circuit

and the component values of:

R1 – 1KΩ
R2 – 100KΩ
R3 - 330Ω
C - 10μF

- 1) Calculate  $f$ ,  $t_1$ ,  $t_2$  and  $d$  (put in a separate word document using equation editor and starting with the formulas then showing the calculations)
- 2) Visually verify that the LED blinks at the expected rate. If it does not, verify your circuit.
- 3) Now replace the following components:

R1 – $330\Omega$
R2 – $1K\Omega$
C - $1\mu F$

- 4) Calculate  $f$ ,  $t_1$ ,  $t_2$  and  $d$  (show calculations in word document as similar to step 1)
- 5) Connect an o-scope to Pin 3 and Pin 2 and verify the diagram in Fig 2.

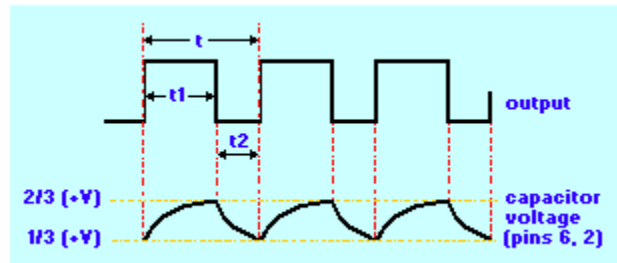

Figure 2- Typical Waveform

- 6) Capture an o-scope image. Edit the image (using paint or similar program) to include the  $t_1$ ,  $t_2$  and  $t$ , include this in the document to submit.
- 7) Using the O-scope, measure the  $f$ ,  $t_1$ ,  $t_2$  and  $d$ . Using a table, record these results in the document and compare the calculated and measured values.
- 8) In the document, discuss the similarities and differences between the measured values and the calculated values for  $f$ ,  $t_1$ ,  $t_2$  and  $d$ . If they do not match, come up with reasonable explanations of why.
- 9) Turn in the document via printout AND online submission (along with a suitable title page) (due start of next lab).