

TECH 3232
Fall 2018
Lab #2
Ver 1.02
Combinational Logic Circuits

Name: _____

Lab
Procedure:

Given the circuit below:

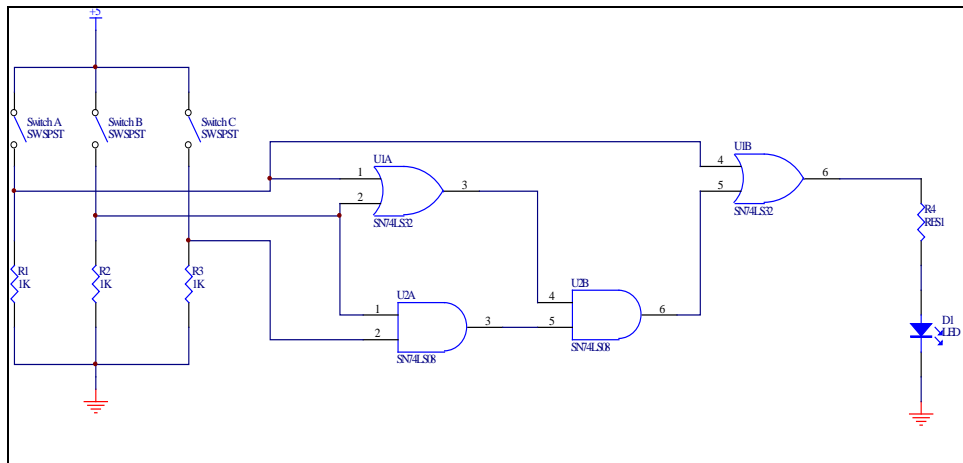

$R4 = 330\Omega$

What is the Boolean logic expression for the circuit?

Using SimcirJS (<http://tech-uofm.info/simcirjs/blank.html>) (available on the class website). Draw and simulate the circuit. Once it is working, hold down the ctrl key and left-click on the mouse within the simulation window (text should appear). Copy all the text in the window and paste it into notepad++ and save it as a .txt file. Submit that file as lab2 sim via the online submission system at <http://tech-uofm.info/upload/upload1.php>

Using the **simulation**, complete the theoretical truth table for the circuit:

Inputs			Output
A	B	C	Z

Now build the circuit using ONE 74LS08, ONE 7432 IC, ONE 1K SIP resistor, ONE DIP Switch, ONE 330Ω resistor and one LED.

We will be using Single Inline Package (SIP) Resistors for this experiment. A SIP resistor has multiple resistors that have one side of each resistor tied to a common pin. This pin can be connected to ground for PULL DOWN resistors and to Power in the case of PULL UP resistors. Pin one of the SIP (the common pin) can be identified by a dot, as shown below:

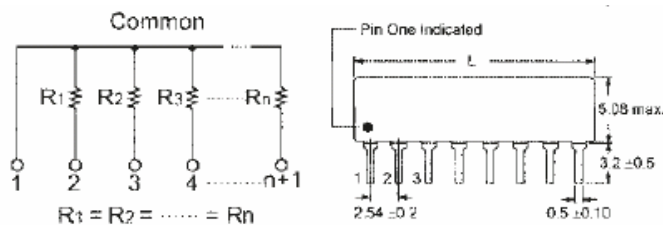

HINTS!:

If the IC is new and never used, straighten all leads on each side by placing the IC on its side on the bench and press firmly on it in order to bend the pins to a 90-degree angle.

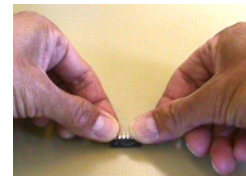

¹ <http://www.physics.mcmaster.ca/phys4d06/Lab/chapter5.htm>

Connect +5V and GND to vertical rails on the solderless breadboards. Distribute these to all other vertical rails to create +5V and GND buses. Use wire of the same colour for all +5V connections, e.g. red, orange or yellow. Use another color for GND, e.g. black, brown, green, blue.

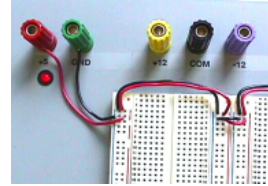

Connect the Vcc and GND pins of the IC to the power bus using short jumpers. Be consistent with use of color.

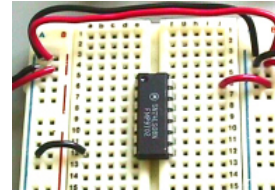

Make use of colored wires to differentiate different connections.

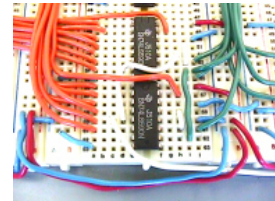

Try to keep all wiring short and tidy and avoid laying wires over the IC, just in case you have to remove the IC. Make use of colors to differentiate the signal functions.

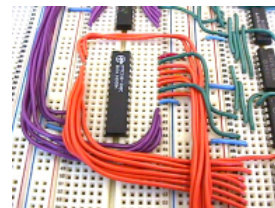

Once connected *complete the truth table below using the constructed circuit:*

Inputs			Output
A	B	C	Z

Demonstrate your circuit to the instructor and have him initial below:

NOTE:DO NOT DESTROY THIS CIRCUIT

Does the truth table from the simulation match the one from the circuit? If you answer no....stop and ask for help!

Draw the circuit (by hand) for the Boolean expression below:

$$Z = A + BC$$

Number the pins for the gates (above) with the next gates on the IC's already in use (on the AND IC, gates on pins 1,2,3 and 4,5,6 are in use and on the OR IC gates on pins 1,2,3 and 4,5,6 are also in use). Refer to the data sheet for the pin numbers of gates not in use.

Without destroying the 1st circuit, wire the circuit (above) using the same switch inputs already in use. Use a 2nd LED for the new output connecting it in series with a second 330Ω resistor.

Once connected, complete the truth table for the new output:

Inputs			Output
A	B	C	Z

Do the two circuits have the same truth table? They should.....now prove that the circuits are equal using Boolean algebra:

Demonstrate your circuit to the instructor and have him initial below:

When taking apart your circuit please note the following:

More Hints²:

Do not use your fingers to remove the ICs from the breadboard. Use the flat screwdriver to gently pry away the IC by alternating at **both ends** of the IC. **Do not crowbar the IC from one end.**

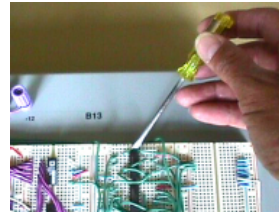

If you bend a pin, carefully bend the pins using needle-nose pliers to straighten them.

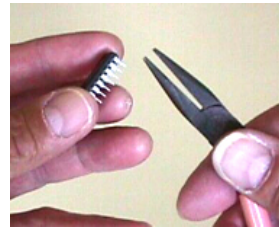

² <http://www.physics.mcmaster.ca/phys4d06/Lab/chapter5.htm>